

ABS | Upright Cabinets

REFRIGERATED UPRIGHT ► WHITE PAINTED

QR 200



GAS R600a		70 mm	A ENERGY CLASS	4 CLIMATIC CLASS	 38°C

DETAILS

 Main switch and digital thermostat fitted as standard	 Foamed door handle	 Lock fitted as standard
 Shelf with small distance between the line and bottom shelf fitted as standard	 Inner assistance fan	



GENERAL FEATURES

- 200 Lt. Refrigerated upright
- White external cabinet, thermoformed internally
- Roll-bond evaporator system with fan assisted cooling
- Automatic compressor cycle defrost
- Foaming Agent Cyclopentane (70mm per side)
- Digital Thermostat
- Independent back-lit main switch (White color)
- Removable Gasket and handle along door profile
- Reversible door (No self closing)
- Doors lock fitted as standard
- Adjustable shelves: 2 Pcs + 1 BOTTOM Shelf
- N.2 Adjustable feet + N.2 Rollers at the back
- Energy efficiency class: A

TECHNICAL SPECIFICATIONS

Capacity	200 L
Temperature	+0°C - +10°C
Consumption	0.93 kWh/24h
Rated Power	120 W
Noise level	52 dB(A)
Net Weight	37 Kg
Gross Weight	41 Kg
External Dimensions (WxDxH mm)	600x625x853
Internal Dimensions (WxDxH mm)	458x465x603
Packaging dimensions (WxDxH mm)	640x660x890
Loading quantities 20'/40'/40'HQ	54/108/162

PRODUCT DIMENSIONS

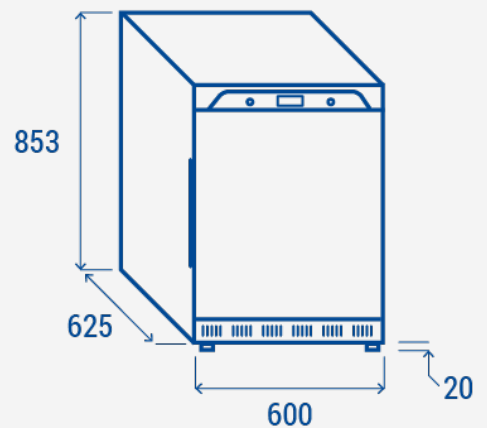

CERTIFICATION

CE RoHS

